



UKSOL

THE BRITISH SOLAR ENERGY SPECIALIST

# CORPORATE SALES PRESENTATION

© UKSOL January 2019

# UKSOL FOUNDER AND CEO

- Previously lived in UK, USA, Africa and Asia.
- Many years experience in the Solar PV industry.
- Set up a national UK renewable energy sales and installation company in 2006.
- Joined a German solar PV manufacturer, Antaris Solar, in 2011 as International Sales Director.
- Took Antaris Solar company into Japan, Thailand, India, South Africa, Cambodia, Philippines, UAE and many other countries around the world as their International Sales Director.
- Founded UKSOL to launch a different kind of British solar PV module producer with a stronger emphasis on quality and exclusive partnerships to protect distributors and installers.
- UKSOL is now a global provider of high quality solar PV modules and other PV products.



# WHO ARE WE?



UKSOL Ltd is a private British-owned company based near London, UK.



British-based procurement, technical and customer support.



UKSOL has English management with extensive experience in the solar industry.



UKSOL has developed a unique exclusivity scheme to protect local partners.



We produce high quality solar PV panels always using grade A cells.



100% British owned and run.



We deliver globally.



# WHY BUY FROM GREAT BRITAIN?

- A very distinctive British brand. Stand out from the crowd!
- Surprisingly low prices!
- Safe procurement through British banks
- UK-based customer support in English
- Protection through exclusivity
- Your end-users and customers will love the UKSOL brand!
- Safe, low risk, long-term support and warranties



# UKSOL PARTNERSHIP WITH THE BRITISH GOVERNMENT



Department for  
International Trade



PROUD TO SUPPORT  
**GREAT**  
BRITAIN & NORTHERN IRELAND



# THE UKSOL MODEL



FROM LONDON: DESIGN · PROCUREMENT · WARRANTY · SUPPORT · DISTRIBUTOR SALES · QUALITY CONTROL

QUALITY CONTROL

CERTIFICATION & TESTING



CHINA  
FACTORY



MIDDLE EAST  
FACTORY



EUROPEAN  
FACTORY



EXCLUSIVE COUNTRY DISTRIBUTORS

INSTALLERS

PROJECTS

# UKSOL ADDS VALUE TO YOUR SOLAR BUSINESS

LATEST PANEL TECHNOLOGY

WE HELP BUILD YOUR  
BUSINESS TO GROW!

LEAD GENERATION

LONG TERM LOYALTY



COMPETITIVE PRICES

WE CARE!

LONG-TERM WARRANTY  
SUPPORT

HIGH QUALITY PRODUCT

# THE PROTECTION OF LOCAL UKSOL EXCLUSIVITY



**CAN ONLY BE BOUGHT FROM EXCLUSIVE DISTRIBUTORS AND INSTALLERS**

We have a close partnership

Gives confidence and protection to market UKSOL locally

UKSOL panels are only available from you

All local orders come back to you from your local marketing



**CAN BE BOUGHT FROM YOUR COMPETITORS WHOLESALERS/DISTRIBUTORS  
END USERS CAN BUY DIRECT FROM CHINA**



**Too big to care?**

**To compete with others selling the same brand you have to keep quoting lower!**

End users can bypass the local distributor/installer because they can buy anywhere



# BECOME A UKSOL DISTRIBUTOR

The UKSOL Concept: The more you invest in local marketing the more orders you will get



**Exclusive  
Local  
Distributor/installer**

**Container purchase establishes local stock**

**Own project sales**

Two ways to  
grow YOUR  
sales

**Sell to other  
installers**

# UKSOL IN JAPAN: TOUGH MARKET TO BREAK INTO!

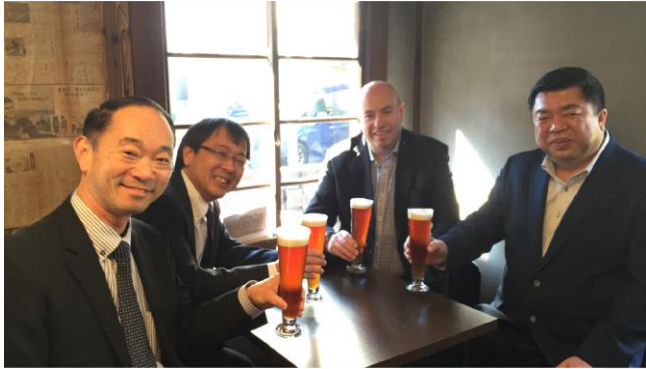

The image shows a screenshot of the UKSOL website. At the top, the UKSOL logo is displayed against a blue sky background. Below the logo is a navigation menu with links for 'ホーム' (Home), 'UKSOLとは' (About UKSOL), '製品案内' (Product Information), '製品保証' (Product Warranty), '性能保証' (Performance Warranty), and 'お問い合わせ' (Contact Us). The main content area features a headline: 'UKSOLのソーラーパネルは高品質かつ低価格で優れたコストパフォーマンスをご提供します' (UKSOL solar panels provide high quality, low cost, and excellent cost performance). Below this are two columns of text and images. The left column features a UK flag and text stating that UKSOL is a British solar panel brand with a focus on high quality and low cost. The right column features an image of solar panels and text stating that UKSOL uses the best quality cells and provides excellent performance. At the bottom, there are two large callouts: '12年製品保証' (12-year product warranty) and '30年性能保証' (30-year performance warranty). On the right side of the website, there is a sidebar with the UKSOL logo, contact information for UKSOL Japan (株式会社クリーンエナジー), and social media icons for Facebook, Twitter, Google+, and LINE.

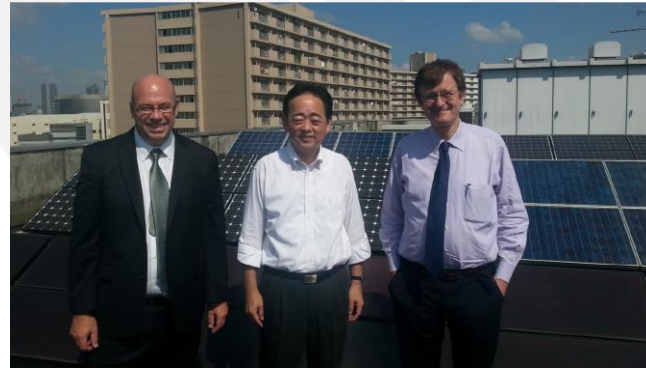

# EMERGING MARKETS: UKSOL UKRAINE

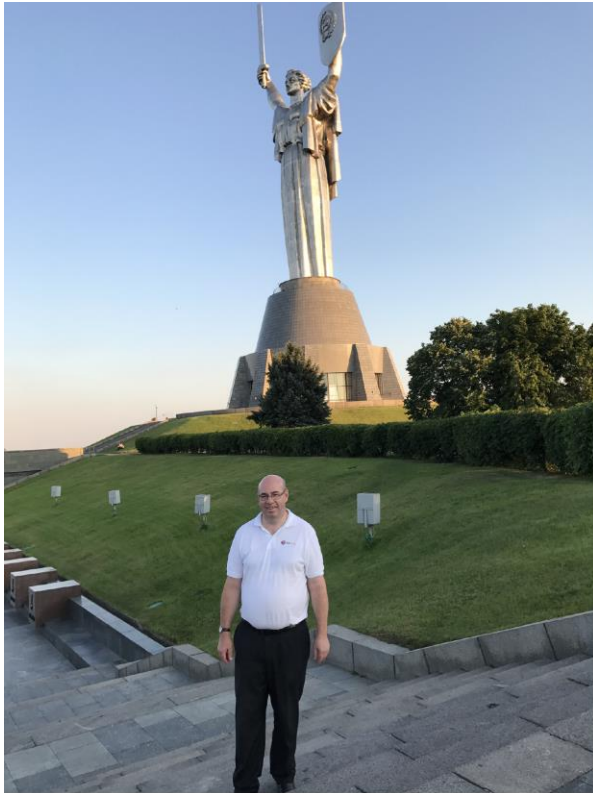

**MTI**

# UKSOL PHILIPPINES



Barend Luger  
Country Manager, Philippines



# UKSOL VIETNAM



# UKSOL SRI LANKA



New branch opening in Anuradhapura



**EXCLUSIVE  
DISTRIBUTOR**  
SUNLEAF SOLAR,  
SRI LANKA

# UKSOL JORDAN



# UKSOL SAUDI ARABIA





# UKSOL MOROCCO



# UKSOL KENYA

Land Cruiser



Land Rover



Hiace



OPIBUS

Electric Drive Train



EV Charger



Hybrid Inverter



PV System



Lithium Storage



# UKSOL NIGERIA

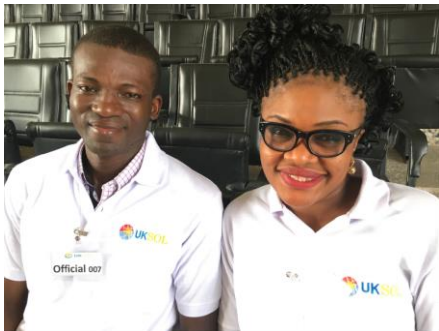

# UKSOL MALI



# UKSOL EL SALVADOR



# UKSOL BRAZIL



## Energia (Elétrica)

Fabricante

Marca

Modelo

MÓDULO FOTOVOLTAICO

WEMN Co.  
LIMITED  
UKSOL

UKS-6P30-270W

Mais eficiente

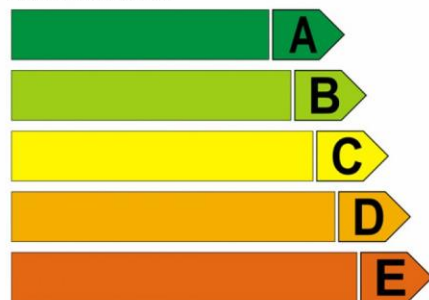

Menos eficiente

EFICIÊNCIA ENERGÉTICA (%)

16,6

Área Externa do Módulo (m<sup>2</sup>)

1,63

Produção Média Mensal de Energia (kWh/mês)

33,75

Potência nas Condições Padrão (W)

270

Requisitos de Avaliação da Conformidade para Sistemas e Equipamentos para Energia Fotovoltaica

Instruções de instalação e recomendações de uso, leia o Manual do aparelho



**PROCEL**

PROGRAMA NACIONAL DE  
CONSERVAÇÃO DE ENERGIA ELÉTRICA



IMPORTANTE: A REMOÇÃO DESTA ETIQUETA ANTES DA VENDA ESTÁ EM DESACORDO COM O CÓDIGO DE DEFESA DO CONSUMIDOR



# UKSOL MEXICO

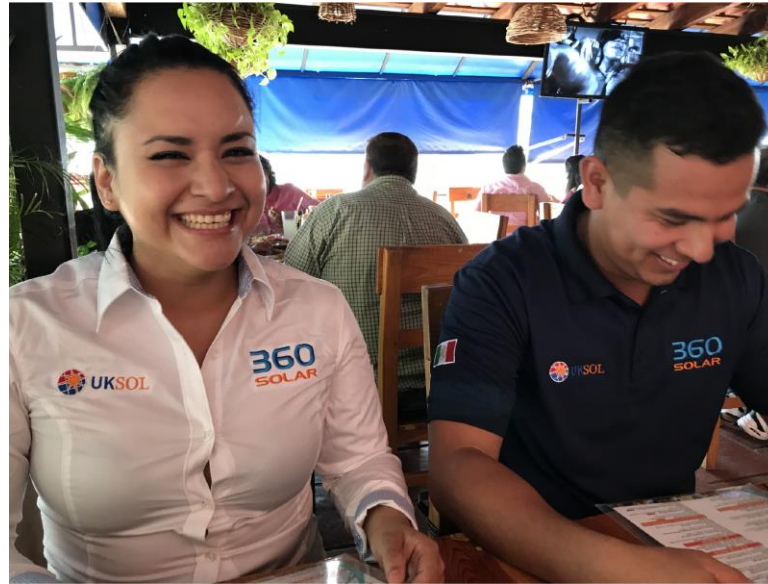

# UKSOL COLOMBIA





# UKSOL MONGOLIA



# UKSOL SUPPLIES BOTH LARGE & SMALL PROJECTS



# UKSOL 2.3MW PROJECT MANILA

One of the largest roof top projects in the Philippines!



UKSOL MODULE PORTFOLIO  
60 & 72 CELLS · 5 BUS BARS · PERC CELLS



**12 YEAR  
PRODUCT  
WARRANTY**



**30 YEAR  
PERFORMANCE  
WARRANTY**

**MONO PERC**  
280 – 370w



**ALL BLACK MONO  
OR POLY**  
280 – 370w



**POLY**  
280 – 340w



# WHY OUR SOLAR PANELS STAND OUT

 Always grade "A" cells

 4 or 5 bus bars

 Automated production line

 PID free.

 TUV Sud certified

 PI Institute Berlin tested

 Double Glass available

 Ammonia tested & Salt spray tested

 High wind & hail loads

 High & low temperature tested

 No quibble warranty & UK based customer services

 Special glass coating

 PERC Cells

 Bi-facial available



# TRUSTWORTHY WARRANTIES

- 30-year (80%) performance warranty
  - Guaranteed 90% of output up to 10 years
  - Guaranteed 80% of output up to 30 years
- 12-year product warranty – we swap the panel for a new one if there are defects!
- Stable British company to support the warranty long term
- UKSOL reduces the risk to YOUR business.
- We ensure you get service quickly if you are not happy with anything
- Who will you call when things go wrong? Will your current supplier be there for you?



# CONTAINER QUANTITIES

No. of Cells	Typical Output	Panel dimensions	20 FT Container Quantity	40 FT HQ Container Quantity	Pallet Quantities
60 cells	280w+	1640 x 992 x 35 mm	360 panels	896 panels	30
72 cells	330w+	1956 x 992 x 40 mm	260 panels	616/696 panels	26



# PRODUCTION TIMES & PAYMENT TERMS

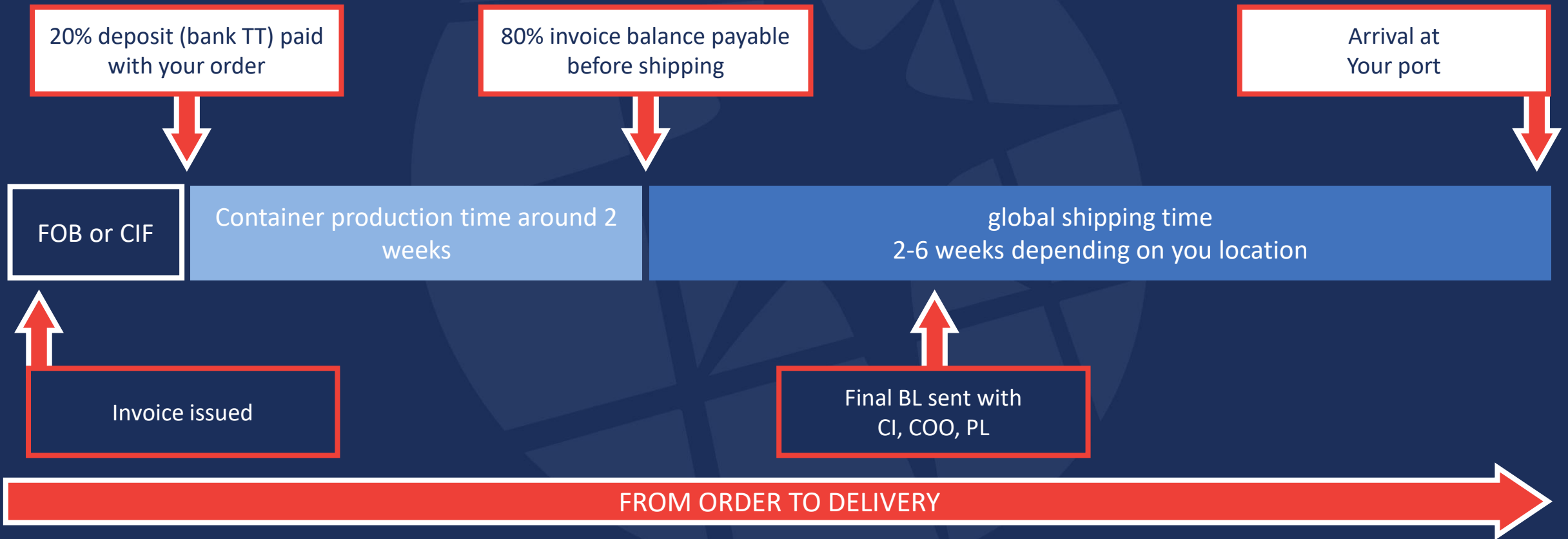







Payment is made in US Dollars into a Santander Dollar account held in England by UKSOL Ltd.



# PARTNER PRODUCTS: MOUNTING SYSTEMS

 We supply best-of-breed mounting and racking systems from the best manufacturers:

-  Roof top
-  Ground mounting
-  Flat roofs
-  Utility scale
-  Minimum order is 50kw
-  Competitive prices

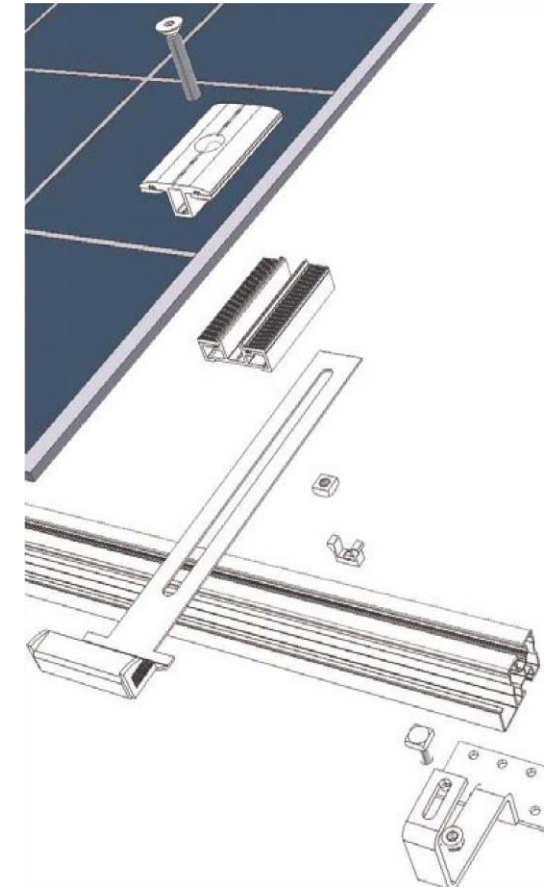

# PARTNER PRODUCTS: INVERTERS

 We supply best-of-breed inverters from the best manufacturers

 On grid – string inverters

 On grid – micro inverters

 Hybrid - inverters

 Off-grid inverters

 Utility scale projects

 Minimum order is 10 units

 Main dealer for Kaco and Sungrow

 Competitive prices

UKSOL supplies inverters from...

**SUNGROW**

**K A C O**



new energy.



# INVERTERS: LARGE SCALE PROJECTS



4 pcs SG500/630MX



MV Transformer



MV Switchgear



Monitoring and  
LV distribution

# UTILITY SCALE MW PROJECTS

- UKSOL can provide full support for large scale MW projects
- We can provide:
  - Low-risk procurement via British banks – panels, inverters, racking, cabling etc
  - Links to EPC companies
  - Reliable global supply chain management
  - Long-term warranty support
  - Call for details of how we can help deliver your project



# WHY IS UKSOL DIFFERENT?

- EXCLUSIVITY opportunity. Build the UKSOL brand and get all the sales in your area! No competition!
- We provide you with lead generation, online training and business support.
- Strong emphasis on long term partnership with our dealers.
- We care about the growth of your business.
- Longest warranties on the market – British backed.
- Competitive pricing.
- We give smaller to medium-sized solar companies the opportunity to compete.

# CONTACT US

**TELEPHONE:** +44 (0)1753 910327

 **WhatsApp:** +44 7949 489911

**EMAIL:** info@uksol.uk



[WWW.UKSOL.UK](http://WWW.UKSOL.UK)

1 Chalfont Park, Gerrards Cross,  
Buckinghamshire, SL9 0BG, UK



LOW RISK BRITISH  
PROCUREMENT



BRITISH TECHNICAL  
SUPPORT



ALWAYS GRADE  
"A" CELLS



BRITISH QUALITY  
STANDARDS